

Alwin Manufacturing Co, Inc., d.b.a. E-Z Taping Systems®  
Design Number EZT/WA 60-02  
Joint Tape  
Flame Fighter Fire Tape®  
ASTM E119, UL 263, NFPA 251, CAN/ULC S101  
Fire Resistance Rating – 1 hour

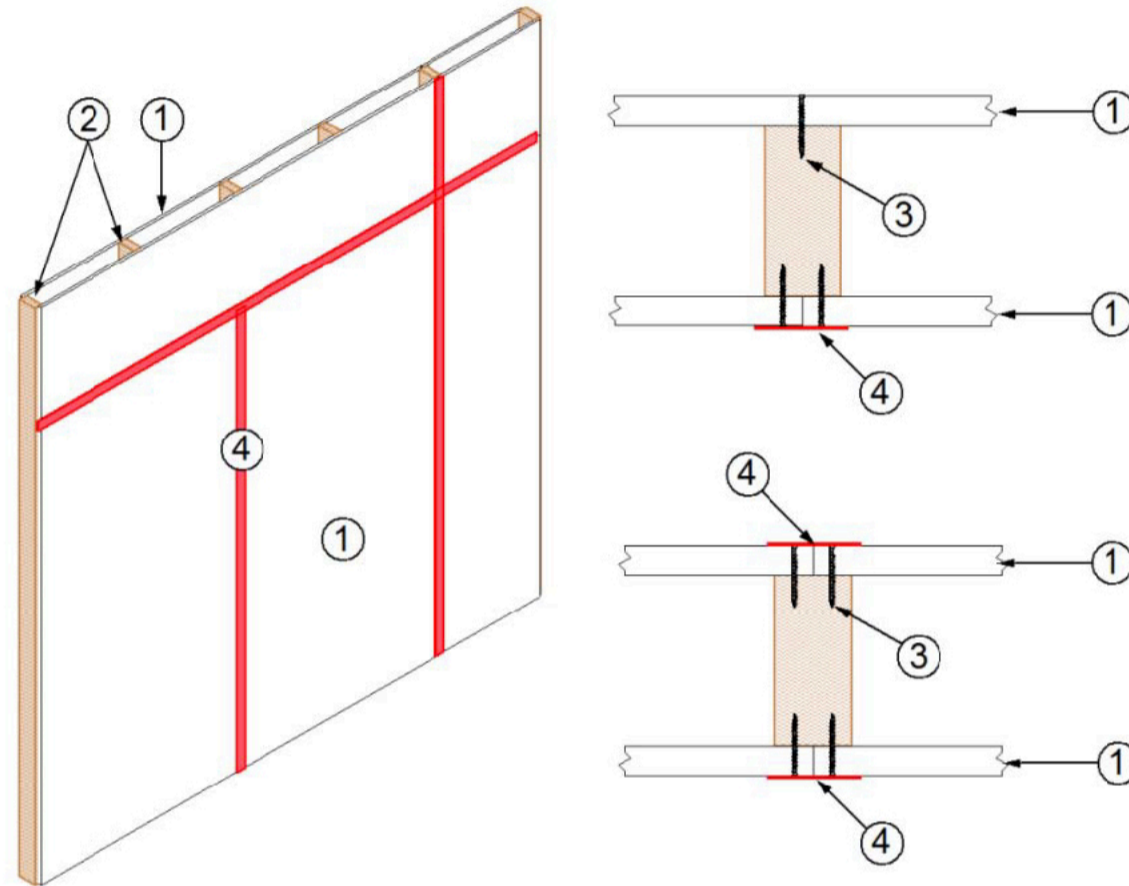

**Figure 1 – Wall Assembly & Details**

1. GYPSUM BOARD - Select any 1-hour, fire-resistance rated, loadbearing or non-loadbearing, wall assembly comprised of wood stud framing (Item 2) clad with gypsum board under Intertek's Design Number Designated WA-60, Wall Assembly, or under UL's Category BXUV and ULC's Category BXUV7, Wall and Partition, Design Numbers 300-399 under Designations U, V and W; or under the Gypsum Association's GA-600, Fire Resistance Design Manual under GA File Numbers 3000-5999 under Designation WP,

*Wood Framed Walls & Partitions.* Gypsum board panel's nominal thickness shall be as specified in the specific Intertek or UL Design Number selected. Gypsum board panels shall comply with ASTM C1396/C1396M, *Standard Specification for Gypsum Board*; ASTM C1177 *Standard Specification for Glass Mat Gypsum Substrate for Use as Sheathing*; or ASTM C1658 *Standard Specification for Glass Mat Gypsum Panels* and be Listed and Labeled under a recognized third-party Listing and Follow-up Program. Gypsum



board panels shall be installed in accordance with ASTM C840, *Standard Specification for Application and Finishing of Gypsum Board*, and GA-216 *Application and Finishing of Gypsum Panel Products*. All vertical joints of gypsum board panels shall be tightly abutted and centered over wood studs. All horizontal joints of gypsum board panels shall be tightly abutted and offset minimum of 12 in. between opposing gypsum board wall assembly faces.

2. WOOD FRAMING – Wood studs and tracks shall be as specified in the specific Design Number compliant with Item 1 for size and grade as well as attachments and length of wood studs in relationship to distance between wood sole and top plates (not shown). Wood stud cavities can be either empty or filled with insulation as specified in the specific Design Number compliant with Item 1.
3. FASTENERS – Spacing pattern, length, and diameter of fasteners shall be as specified in the specific Design Number compliant with Item 1. Use Type S or Type W screws for attaching gypsum board panels (Item 1) to wood framing members (Item 2) and screws shall comply with ASTM C 1002, *Standard Specification for Steel Self-Piercing Tapping Screws for Application of Gypsum Panel Products or Metal Plaster Bases to Wood Studs or Steel Studs*.
4. CERTIFIED MANUFACTURER: E-Z Taping Systems®  
CERTIFIED PRODUCT: Joint Tape  
  
CERTIFIED MODEL: Flame Fighter Fire Tape®  
  
JOINT TAPE – Use patented, multi-layer, fiberglass reinforced, Flame Fighter Fire

Tape® with pressure sensitive adhesive tested to requirements for joint tape under ASTM C474, *Standard Test Methods for Joint Treatment Materials for Gypsum Board Construction*, complying with requirements for joint tape under ASTM C475, *Standard Specification for Joint Compound and Joint Tape for Finishing Gypsum Board*.

- A. Flame Fighter Fire Tape® is typically used as a Level 1 Finish as described in GA-216, *Recommended Specifications for the Application and Finishing of Gypsum Panel Products*, (ASTM C840, *Standard Specification for Application and Finishing of Gypsum Board*) because it is not required to be set in or covered by joint compound. Level 1 Finish applications are typically used in unfinished parts of the building where aesthetics are not an issue, such as in plenum areas above ceilings, in attics, in areas where the assembly would generally be concealed or in building service corridors; and other areas not normally open to public view or such as in corridors, storage rooms, garages, parking structures, and other similar areas.
- B. Center and apply Flame Fighter Fire Tape® over the vertical and horizontal gypsum board panel (Item 1) butt joints covering the butt joint and fasteners (Item 3). The butt joints and angles of the gypsum board panels (Item 1) shall be clean, e.g. free of dust or powder, and completely dry prior to the application of Flame Fighter Fire Tape®. The pressure sensitive adhesive shall be in



complete contact with the adjacent  
gypsum board panel

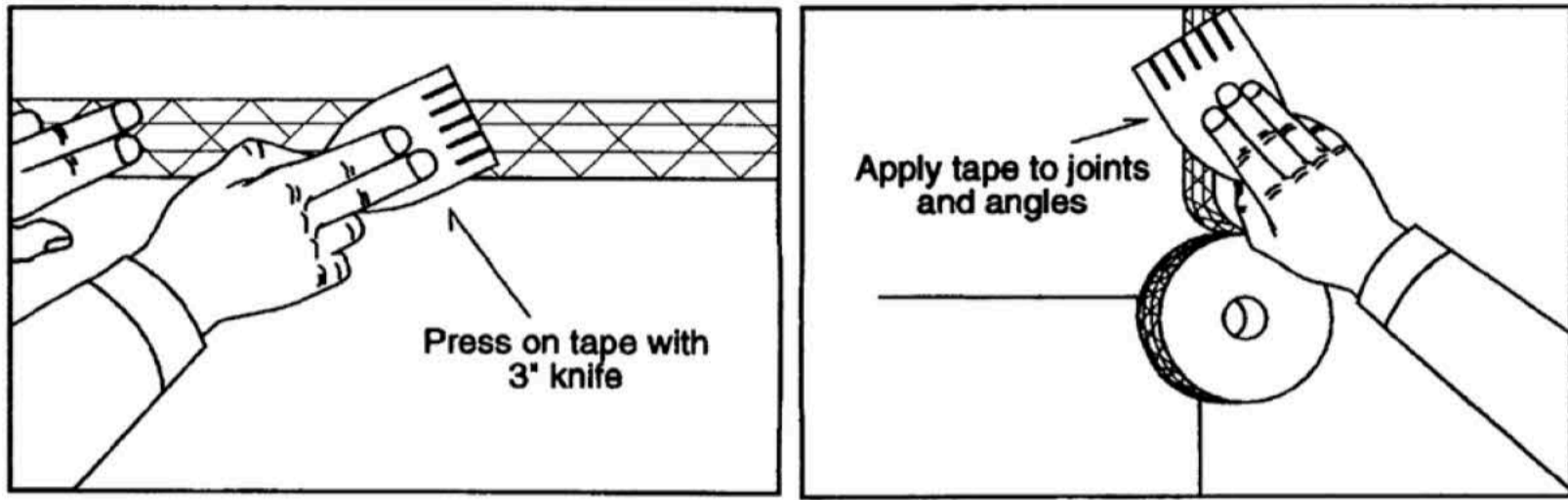

Figure 2 – Installation Methods

(Item 1) surfaces. Apply sufficient pressure to the Flame Fighter Fire Tape® using the E-Z Tape 3-in. plastic knife to aggressively adhere the pressure sensitive adhesive to the gypsum board panels' (Item 1) surfaces. Do not use your hand or any other tool because sufficient adhesion of the Flame Fighter Fire Tape® to the gypsum board panels (Item 1) will not be achieved. Use a corner roller to adhere Flame Fighter Fire Tape® to inside and outside gypsum board panel (Item 1) corners, e.g. angles.

- C. The exposed outer surface of the Flame Fighter Fire Tape® is treated with silicone. Do not overlap Flame Fighter Fire Tape® onto itself because it will not adhere to itself. At intersections of Flame Fighter Fire Tape®, e.g. "L", "⊥" and "T", abut the leading edge of the Flame Fighter Fire Tape® to the longitudinal edge of the Flame Fighter Fire Tape® being intersected.

- D. Joint compound and paint will not adhere to Flame Fighter Fire Tape® without the application of an oil-based primer. When paint or a Level 2 or a Level 3 Finish using joint compound is desired, a compatible primer is required to promote adhesion to Flame Fighter Fire Tape®. A *Rustoleum*® primer called Zinsser® Bulls Eye® Odorless<sup>1</sup> has been found suitable to coat over Flame Fighter Fire Tape® to promote adhesion to Flame Fighter Fire Tape®. After the primer is applied in accordance with the manufacturer's instructions and completely dry, joint compound or a latex paint can be applied over Flame Fighter Fire Tape®.

- E. Use only rolls of Flame Fighter Fire Tape® bearing the Intertek Mark for the United States (US) and Canada (C).

<sup>1</sup> <http://www.rustoleum.com/product-catalog/consumer-brands/zinsser/primer-sealers/odorless-oil-base-stain-blocker/>