



8431 Murphy Drive
Middleton, WI 53562

Telephone: 608 836 4400
Facsimile: 608 831 9279
www.intertek-etlsemko.com

24 April 2014

Skip Romagnoli
Sales Manager
All Products. LLC
Green Bay, WI

RE: E-Z Taping Systems (All Products, LLC – Green Bay, WI) Listings

Dear Mr. Romagnoli:

This is to confirm that Intertek Testing Services has evaluated the application of the E-Z Taping Systems, Inc. "Fire Tape" for application to the surface joints in 2-hour fire wall constructions as described in the attached listings. I hope that this information will be sufficient to resolve any questions you have.

Please feel free to contact me if you need any more information.

Sincerely,

Rick Curkeet, PE
Chief Engineer – Building Products



DESIGN NO. EZT/WA 120-01
ASSEMBLY RATING - 2 HOURS, NON-BEARING WALL

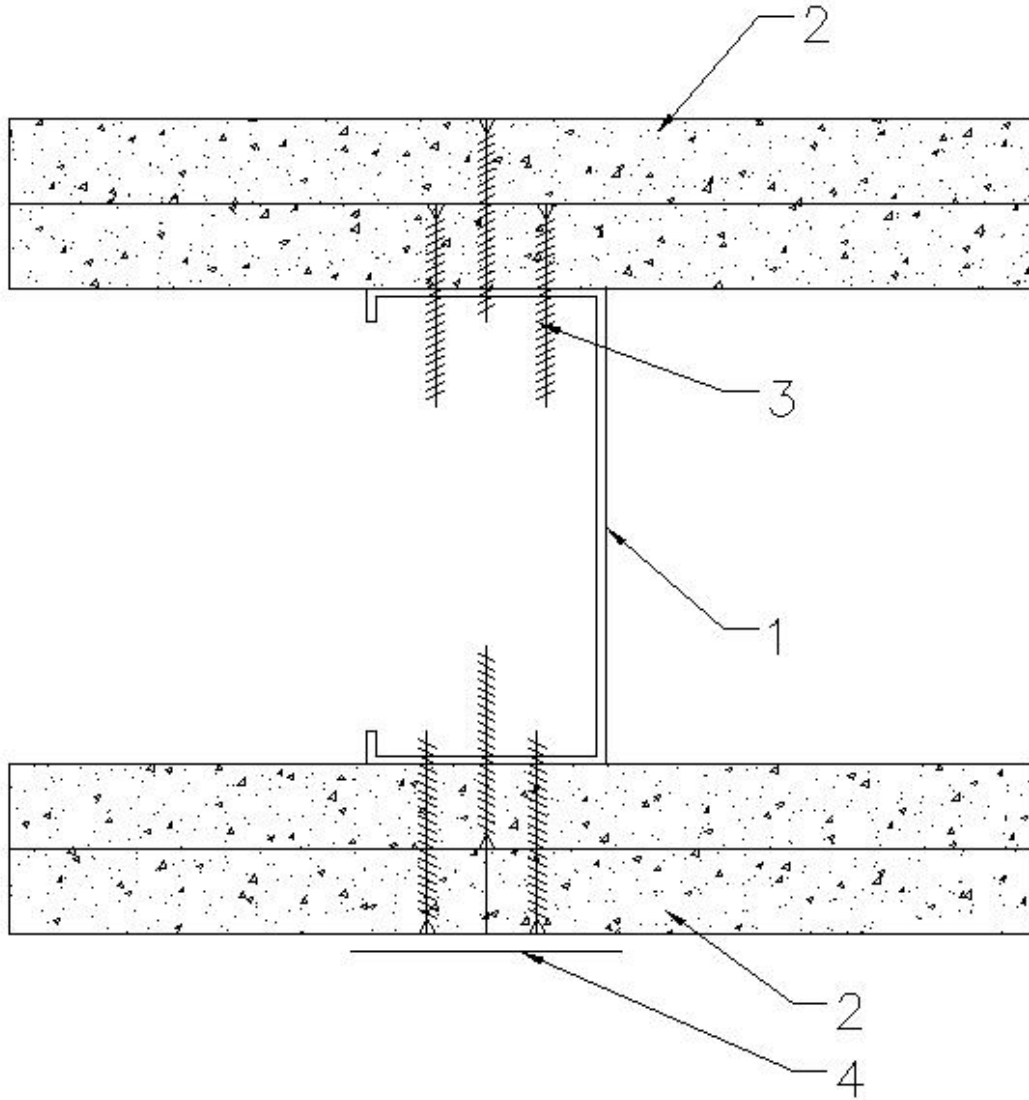

Steel Studs: 'C' Shaped 3-5/8" minimum deep, fabricated from minimum 0.019" thick galvanized steel. Cut to length 1/2" less than the openings height and spaced 24" maximum oc.

Gypsum Board: Two (2) hour rated walls have two (2) layers of 5/8" Type 'X' gypsum wallboard panels on each side of the steel studs. The "Fire Tape" product would be used as an alternative to conventional joint tape in specific systems when:

1. Two or more layers of listed Type 'X' gypsum wallboard are applied vertically with joints staggered and the joints of the face boards are:
 - a. Tightly butted and taped with EZ Taping Systems "Fire Tape" or
 - b. Finished with joint compound of EZ Taping Systems "Fire Tape" if the gap between gypsum wallboard panels are visible at the joint.
2. Two or more layers of USG "Sheetrock" Firecode C gypsum wallboard are applied (horizontally or vertically).
 - a. The panels shall be tightly butted with the joints staggered and taped with EZ Taping Systems "Fire Tape".

b. If a gap is visible at the joint, a finishing coat of joint compound over the EZ Taping Systems "Fire Tape" would be required.

Attachment: 1-1/8" long, Type S drywall screws, spaced 8" oc to vertical edges and 12" oc to top and bottom runners and intermediate studs.

"Fire Tape"*: Nominal 2" (48mm) wide EZ Taping System, Inc. Fire Tape applied on the vertical joints at studs.

*Components bearing the Warnock Hersey Certification Mark.

Testing Standards: CAN/ULC-S101, NFPA-251, UL-263.

▼ **DESIGN NO. EZT/WA 120-02**

**DESIGN NO. EZT/WA 120-02
ASSEMBLY RATING - 2 HOUR, BEARING WALL**

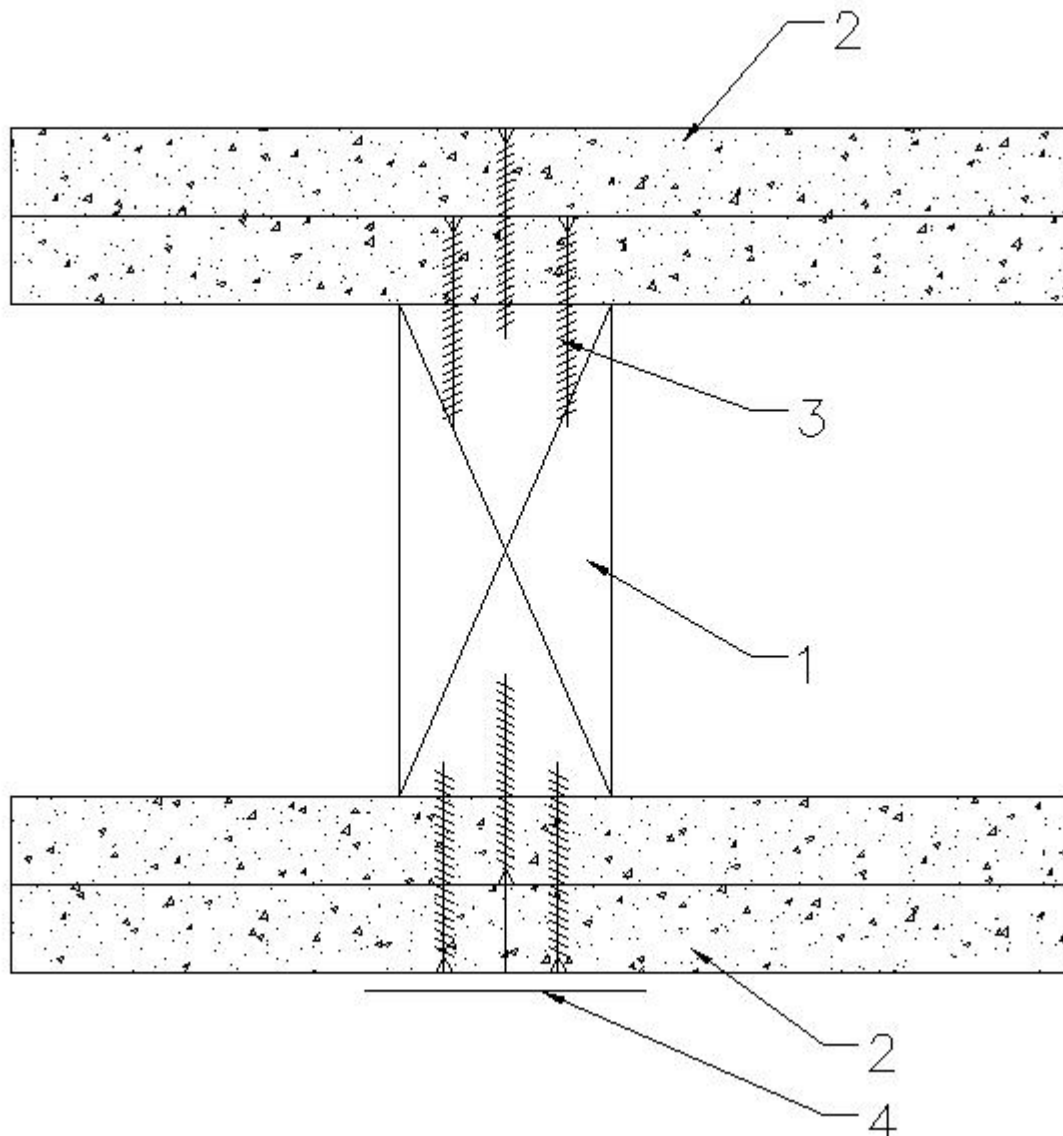

Studs: Nominal 2" x 4" wood studs, spaced maximum 16" oc with mid-height bridging.

Gypsum Board: Two (2) hour rated walls have two (2) layers of 5/8" Type 'X' gypsum wallboard panels on each side of the steel studs. The "Fire Tape" product would be used as an alternative to conventional joint tape in specific systems when:

3. Two or more layers of listed Type 'X' gypsum wallboard are applied vertically with joints staggered and the joints of the face boards are:

- a. Tightly butted and taped with EZ Taping Systems "Fire Tape" or
- b. Finished with joint compound of EZ Taping Systems "Fire Tape" if the gap between gypsum wallboard panels are visible at the joint.

4. Two or more layers of USG "Sheetrock" Firecode C gypsum wallboard are applied (horizontally or vertically).

- a. The panels shall be tightly butted with the joints staggered and taped with EZ Taping Systems "Fire Tape".
- b. If a gap is visible at the joint, a finishing coat of joint compound over the EZ Taping Systems "Fire Tape" would be required.

Attachment:

- a) 1-1/4" long, Type W drywall screws, spaced 8" oc to vertical edges and 12" oc to top and bottom runners and intermediate studs.
- b) 1-7/8" long, 0.0915" Shank, 1/4" Head, nailed at 7" oc.

"Fire Tape"*: Nominal 2" (48mm) wide EZ Taping System, Inc. Fire Tape applied on the vertical joints at studs. Finishing coat of joint compound applied over EZ Taping System, Inc. Fire Tape is required.

*Components bearing the Warnock Hersey Certification Mark.
Testing Standards: CAN/ULC-S101, NFPA-251, UL-263.

Design listings are based on, and supported by, proprietary test reports. The test reports further define proprietary design details which make these listings applicable only to the specified products manufactured by the listed manufacturer.

Unless otherwise noted, the assemblies in this section have been evaluated for conformance to the following standards:

ASTM-E119, Standard Methods of Fire Tests of Building Construction and Materials.

CAN/ULC-S101, Standard Methods of Fire Endurance Tests of Building Construction and Materials.

NFPA-251, Fire Tests of Building Construction and Materials.

UBC-7-1-94, Uniform Building Code Standard.

UL-263, Fire Tests of Building Construction and Materials.

Designs listed are minimum construction requirements to achieve fire rating.

Unless otherwise ed, fire ratings apply to tests conducted on both sid: Design No. 408 is not used in this edition.